



VISCOELASTIC SHOCK ABSORBERS / AUTOMATIC STROKE RETURN

BA1 range from 0,1 to 14 kJ



Technology

The shock absorbers are designed on the principal of compression of hydrostatic viscoelastic fluids. The viscosity and the compressibility of our fluids allow in a same device to obtain both functions the one of a shock absorber and the one of a spring, without the need of any additional rearming mechanism (gas or mechanical spring). The two functions can be used separately or in combination, in the same product.

Advantages

- Simple design – High reliability
- High damping coefficient
- Low sensitivity to temperature variances
- Security by integrated static preload
- Simple integration

Applications

Protection against shocks in Industry, Material Handling, Rolling Mill, Railway, Defence, Waterways, Paper industry, ...

BA1: Rear flange mounting

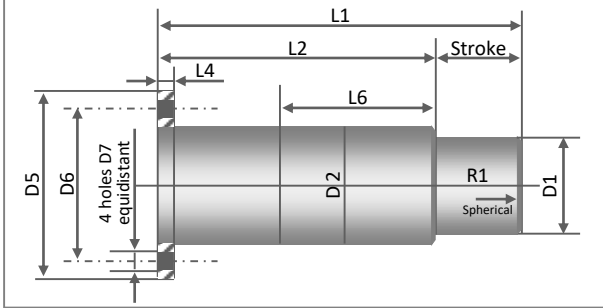

BA1: Nuts mounting

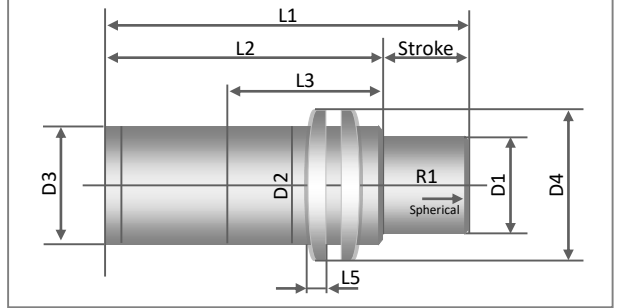

DIMENSIONAL CHARACTERISTICS

	L1 mm	L2 mm	L3 mm	L4 mm	L5 mm	L6 mm	R1 mm	D1 mm	D2 mm	D3 mm	D4 mm	D5 mm	D6 mm	D7 mm	Mass kg
BA1ZN	75	53	52	10	7	43	/	∅ 19	M25 x 1,5	∅ 20	∅ 38	∅ 57	∅ 41	∅ 7	0,3
BA1BN	120	98	96	12	8	86	/	∅ 25	M35 x 1,5	∅ 32	∅ 52	∅ 80	∅ 60	∅ 9	0,7
*BA1BNM	120	98	96	12	9	/	/	∅ 25	M40 x 1,5	∅ 32	∅ 56	/	/	/	0,8
BA1DN	175	140	138	12	11	128	/	∅ 38	M50 x 1,5	∅ 45	∅ 70	∅ 90 ∅ 106	∅ 70 ∅ 85	∅ 9 ∅ 11	1,9 2
*BA1DNM	175	140	138	12	11	/	/	∅ 38	M60 x 2	∅ 45	∅ 81	/	/	/	2
BA1EN	213	168	158	10	13	158	R.130	∅ 60	M75 x 2	∅ 72	∅ 98	∅ 122	∅ 100	∅ 11	5
BA1FN	270	210	130	12	16	130	R.150	∅ 74,5	M90 x 2	∅ 90	∅ 120	∅ 150	∅ 120	∅ 13	10,5
BA1GN	337	257	145	14	19	145	R.350	∅ 90	M110 x 2	∅ 110	∅ 145	∅ 175	∅ 143	∅ 18	17

Outside protection: Zn6Fe

*Devices not available on stock (delivery from 8 to 10 weeks according to model and/or quantity)

MECHANICAL CHARACTERISTICS *

	En kJ	Stroke mm	RDYO kN	RDYmax kN
BA1ZN	0,1	12	6	11
BA1BN	0,43	22	14	27
*BA1BNM				
BA1DN	1,5	35	28	60
*BA1DNM				
BA1EN	3,4	45	45	100
BA1FN	7	60	90	150
BA1GN	14	80	130	230

* Based on following data:

- Impact speed: 2 m/s
- Operating temperature: -20°C to +40°C

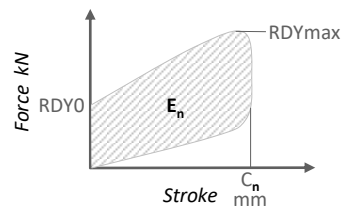

Symbols:

- En = nominal energy capacity
- Cn = maximum stroke
- RDY = dynamic reaction



SELECTION OF A STANDARD SHOCK ABSORBER

BA1 range

1 SELECTION CHART

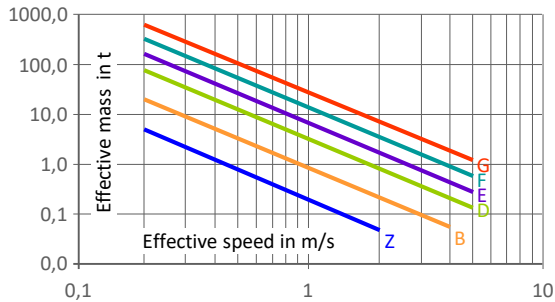

2 EFFECTIVE ENERGY CALCULATION

$$E_e = \frac{1}{2} M_e V_e^2$$

3 ALLOWABLE IMPACT FREQUENCY

$$F < 20 \times \frac{E_n}{E_e} \text{ impacts/hour}$$

4 EFFECTIVE STROKE CALCULATION

$$C_e = C_n \left(\sqrt{\frac{E_e}{E_n(0,03V_e + 0,24)}} + 1,36 - 1,17 \right)$$

5 EFFECTIVE REACTION R_{dy_e} CALCULATION

$$R_{dy_e} = \left[\left(\frac{R_{dy_{max}} - R_{dy0}}{C_n} \right) \times C_e + R_{dy0} \right] (0,1V_e + 0,8)$$

6 APPLICATION EXAMPLE

Given data:

- Effective mass = 15 t
- Effective speed = 0,8 m/s
- Impact frequency = 25 impacts/hour

① Selection chart gives BA1FN.

The mechanical characteristics are:

- E_n = 7 kJ
- C_n = 60 mm
- $R_{dy_{max}}$ = 150 kN
- R_{dy0} = 90 kN

② The energy E_e to dissipate per impact is 4,8 kJ.

③ The allowable impact frequency F is $< 20 \times 7 / 4,8$

④ The effective stroke C_e will be 49 mm

$$60 \left(\sqrt{\frac{4,8}{7(0,03 \cdot 0,8 + 0,24)}} + 1,36 - 1,17 \right)$$

⑤ $R_{dy_e} = [(150-90) \cdot (49/60) + 90] \cdot (0,1 \cdot 0,8 + 0,8) = 122 \text{ kN}$

All performance characteristics can be modified.

Please advise us of your specific requirements.

Dyna Shock System SAS

2 rue Magnier Bédu
95410 Groslay - France
Tel : +33 (0) 1 34 17 18 00
Fax : +33 (0) 1 34 12 95 17
Web : www.dyna2s.com